

marathon[™]
Motors



SyMAX[®]
Permanent Magnet AC Motors

SB385

A Regal Brand

REGAL



SyMAX[®]
Commercial 48-56 frame



SyMAX[®]
Industrial – Cast Iron Severe Duty
NEMA 182-286T – IEC 132-180

SyMAX[®] Quick Reference Guide

Motor Selection	1	Permanent Magnet AC Motor Terminology, Formulas and Conversion Factors	9
Models and Pricing	2	Safety Warnings, Terms and Conditions of Sale	10
Performance Data	3	Terms and Conditions of Sale (continued)	11
Dimensional Data	4	Terms and Conditions of Sale (continued)	12
Energy Savings, "Performance-Matched" Drives	5	Frequently Asked Questions	12
SyMAX Commercial motor Features and Benefits	6	Resale of Goods	13
SyMAX Industrial motor Features and Benefits	7	Product Line Comparison	BC
Permanent Magnet AC Motor Terminology	8		

Defining the Next Generation of Power

Since 1913, Marathon Electric has developed a reputation for conservative motor designs and highly engineered products used in a vast array of commercial and industrial applications around the world.

Marathon Electric has built on our legacy of innovation by combining magnetics and motors into a single leading technology. The use of Magnology[™] has led to the development of the next generation of technology in motor efficiency and performance, the SyMAX[®] motor.

The SyMAX permanent magnet AC motors offer unique solutions for today's demanding applications. This product's unparalleled power density, unprecedented performance and unmatched efficiency is another industry first.

Our Founding Principles

- Serve customers according to their needs
- Produce the most efficient and long-lasting motors
- Commit to new technology and research
- Expand and diversify into new markets



SyMAX[®] PMAC Motor selection

Step 1. Determine required torque @ rated speed; identify motor frame size. NOTE: Chart illustrates Power Dense capabilities, not normal NEMA frame sizes.

HP	RPM																Color Key	
	900		1000		1200		1500		1800		2250		3000		3600			
	Lb-Ft	Frame	Lb-Ft	Frame	Lb-Ft	Frame	Lb-Ft	Frame	Lb-Ft	Frame	Lb-Ft	Frame	Lb-Ft	Frame	Lb-Ft	Frame		
0.25	1.5	48	1.3	48	1.1	48	0.9	48	0.7	48	0.6	48	0.4	48	0.4	48	48	
0.33	1.9	48	1.7	48	1.4	48	1.2	48	1.0	48	0.8	48	0.6	48	0.5	48	56	
0.5	2.9	56	2.6	56	2.2	48	1.8	48	1.5	48	1.2	48	0.9	48	0.7	48	143-145T	
0.75	4.4	56	3.9	56	3.3	56	2.6	56	2.2	48	1.8	48	1.3	48	1.1	48	182-184T	
1	5.8	143T	5.3	143T	4.4	56	3.5	56	2.9	56	2.3	48	1.8	48	1.5	48	213-215T	
1.5	8.8	143T	7.9	143T	6.6	143T	5.3	143T	4.4	56	3.5	56	2.6	56	2.2	48	254-256T	
2	11.7	182T	10.5	182T	8.8	143T	7.0	143T	5.8	143T	4.7	56	3.5	56	2.9	56	284-286T	
3	17.5	184T	15.8	184T	13.1	182T	10.5	182T	8.8	143T	7.0	143T	5.3	143T	4.4	56		
5	29.2	213T	26.3	213T	21.9	184T	17.5	184T	14.6	184T	11.7	182T	8.8	143T	7.3	143T		
7.5	43.8	215T	39.4	215T	32.8	213T	26.3	213T	21.9	184T	17.5	184T	13.1	182T	10.9	182T		
10	58.3	254T	52.5	254T	43.8	215T	35.0	215T	29.2	213T	23.3	213T	17.5	184T	14.6	184T		
15	87.5	284T	78.8	256T	65.6	254T	52.5	254T	43.8	215T	35.0	215T	26.3	213T	21.9	184T		
20	116.7	286T	105.0	284T	87.5	256T	70.0	256T	58.3	254T	46.7	254T	35.0	215T	29.2	213T		
25					109.4	284T	87.5	256T	72.9	256T	58.3	254T	43.8	215T	36.5	215T		
30							105.0	284T	87.5	284T	70.0	256T	52.5	254T	43.8	215T		
40									116.7	286T	93.3	284T	70.0	256T	58.3	254T		
50											116.7	286T	87.5	256T	72.9	256T		
60													105.0	284TS	87.5	256T		
75															109.4	286TS		
100																		

Step 2. Determine required operating points and torque profile.

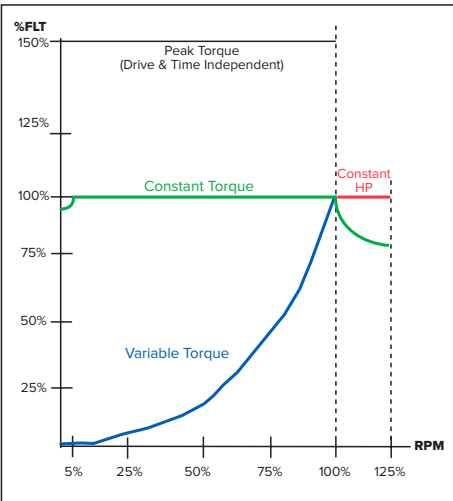

VFD Considerations

While SyMAX[®] motors are designed to operate with multiple brands and models of PM drives, special consideration must be made to ensure optimal drive and motor performance. To ensure a successful application, the following must be addressed. Like the motor application checklist above, this checklist should be considered a tool in addition to consultation with the VFD manufacturer's documentation and advice.

Items to address with the drive manufacturer

- 1) Required software or firmware update, or confirmation of suitability for PM motors.
- 2) Minimum and maximum carrier frequency settings; impact on performance.
- 3) Recommended feedback device and module, if required.
- 4) Special motor parametric data for tuning, if required.
- 5) Maximum allowable Back EMF voltage, to avoid damage to drive components.
- 6) Special ambient conditions, if applicable.
- 7) Special enclosure requirements, if applicable.
- 8) Special performance requirements, if applicable.
- 9) Limitations, such as load sharing, "catching a spinning motor", etc.

SyMAX[®] Application Checklist

To ensure optimal performance from your SyMAX[®] motor, it is important to follow the following checklist. These guidelines are intended to augment sound engineering practice, and therefore should be considered only one tool in applying Permanent Magnet AC motors in various applications.

Basic required data

- 1) Operating speed range and base RPM.
- 2) Torque requirements throughout speed range.
- 3) Description of power supply.
- 4) Make and model of drive (if no preference, so state).
- 5) Description of surrounding environment; specify required protection.
- 6) Frame size limitations and preferences, if any.
- 7) Mounting requirements (base, flange, horizontal, vertical, etc.).
- 8) Belting data, if applicable
- 9) Duty cycle, eg. "continuous", "60 minute", etc.
- 10) Special considerations, eg. load sharing, short accel/decel requirements, etc.
- 11) Special performance requirements.
- 12) Required accessories, modifications and options.

Please consult www.marathonelectric.com for "SyMAX[®] Application Notes".

SyMAX[®] Model Number Nomenclature

Position	Example	Characteristic	Defined Values
1	C	Agency code	C = UL Recognized, no inherent overload protector N = No overload protection, not UL Recognized T = Thermostat, not UL Recognized
2	215T	Frame size	NEMA or IEC frame size designation
3	P	Electrical type	P = Interior Permanent Magnet, Radial Flux Other values to be identified to denote other PMAC
4	F	Enclosure	F = Totally Enclosed, Fan Cooled N = Totally Enclosed, Non-Ventilated P = Partial motor X = Explosion Proof, Fan Cooled (future capability) B = Totally Enclosed, Blower Cooled
5	S	Frame material	S = Cast Iron R = Rolled Steel A = Aluminum
6	A	Style letter	Advanced to denote major design changes
7	1	Product line	1 = Marathon SyMAX [®] PMAC
8	0028	Sequence No.	Sequentially assigned for each unique model
9	A	Revision letter	Advanced to denote minor design changes

SyMAX[®] Stock Models

Standard SyMAX[®] specification except C-Face/Foot mount

HP	RPM	VOLTS	FRAME	CAT. NO.	MODEL NO.	LIST PRICE	MULT. SYMB.	F.L. EFFIC.	F.L. AMPS	WEIGHT (lb)	"C" DIM. (in)
1/2	1800	230/460	56C	SY001	56PNRA10100	\$ 671	PM1	83.5	1.86/0.93	13	7.82
1	1800	230/460	56C	SY003	56PNRA10101	\$ 780	PM1	85.3	3.55/1.78	18	8.82
1 1/2	1800	230/460	56C	SY004	56PNRA10102	\$ 950	PM1	86.1	5.48/2.74	23	9.82
2	1800	230/460	56C	SY005	56PNRA10103	\$1,275	PM1	86.5	6.32/3.16	28	10.82
3	1800	460	182TC	SY006	182TPFSA10094	\$2,056	PM1	91.7	3.8	99	15.88
5	1800	460	184TC	SY007	184TPFSA10095	\$2,281	PM1	91.7	6.4	108	15.88
7.5	1800	460	213TC	SY008	213TPFSA10096	\$2,648	PM1	93.0	9.4	152	19.63
10	1800	460	215TC	SY009	215TPFSA10097	\$3,136	PM1	93.6	11.8	166	19.63
15	1800	460	254TC	SY010	254TPFSA10088	\$3,798	PM1	94.5	18.5	204	25.40
20	1800	460	256TC	SY011	256TPFSA10087	\$4,346	PM1	95.0	22.9	253	25.40
25	1800	460	284TC	SY012	284TPFSA10112	\$5,288	PM1	95.0	28.1	396	27.93
30	1800	460	286TC	SY013	286TPFSA10090	\$6,001	PM1	95.4	33.7	416	27.93

Blue shaded areas are Cast Iron Frames

SyMAX[®] Build-Up Pricing (contact factory for IEC designs)

Normal NEMA Frame Sizes (Direct Drop-In Replacement)

Multiplier Symbol PM1

HP	3600 RPM			1800 RPM			1200 RPM			900 RPM		
	TORQUE	FRAME	LIST	TORQUE	FRAME	LIST	TORQUE	FRAME	LIST	TORQUE	FRAME	LIST
1/2	0.7	See note	\$ 531	1.5	See note	\$ 574	2.2	See note	\$ 628	2.9	See note	\$683
3/4	1.1	See note	\$ 581	2.2	See note	\$ 628	3.3	See note	\$ 741	4.4	See note	\$853
1	1.5	See note	\$ 632	2.9	See note	\$ 683	4.4	See note	\$ 853	5.8	See note	\$1,178
1 1/2	2.2	See note	\$ 789	4.4	See note	\$ 853	6.6	182T	\$1,493	8.8	184T	\$2,062
2	2.9	See note	\$1,090	5.8	See note	\$1,178	8.8	184T	\$2,062	11.7	213T	\$2,886
3	4.4	182T	\$2,248	8.8	182T	\$1,913	13.1	213T	\$2,678	17.5	215T	\$3,214
5	7.3	184T	\$2,512	14.6	184T	\$2,138	21.9	215T	\$2,993	29.2	254T	\$3,592
7.5	10.9	213T	\$2,943	21.9	213T	\$2,505	32.8	254T	\$3,507	43.8	256T	\$4,208
10	14.6	215T	\$3,517	29.2	215T	\$2,993	43.8	256T	\$4,190	58.3	284T	\$5,028
15	21.9	254T	\$4,235	43.8	254T	\$3,604	65.6	284T	\$5,046	87.5	286T	\$6,055
20	29.2	256T	\$4,879	58.3	256T	\$4,152	87.5	286T	\$5,813			
25	36.5	284TS	\$5,852	72.9	284T	\$4,980						
30	43.8	286TS	\$6,689	87.5	286T	\$5,693						

Power Dense Frame Sizes

Multiplier Symbol PM1

HP	3600 RPM			1800 RPM			1200 RPM			900 RPM		
	TORQUE	FRAME	LIST	TORQUE	FRAME	LIST	TORQUE	FRAME	LIST	TORQUE	FRAME	LIST
1/2	0.7	See note	\$ 531	1.5	See note	\$ 574	2.2	See note	\$ 628	2.9	See note	\$ 683
3/4	1.1	See note	\$ 581	2.2	See note	\$ 628	3.3	See note	\$ 741	4.4	See note	\$ 853
1	1.5	See note	\$ 632	2.9	See note	\$ 683	4.4	See note	\$ 853	5.8	See note	\$1,178
1 1/2	2.2	See note	\$ 789	4.4	See note	\$ 853	6.6	See note	\$1,296	8.8	See note	\$1,913
2	2.9	See note	\$1,090	5.8	See note	\$1,178	8.8	See note	\$1,913	11.7	182T	\$1,999
3	4.4	See note	\$1,349	8.8	See note	\$1,913	13.1	182T	\$2,104	17.5	184T	\$2,142
5	7.3	See note	\$1,507	14.6	182T	\$2,138	21.9	184T	\$2,255	29.2	213T	\$2,843
7.5	10.9	182T	\$2,355	21.9	184T	\$2,255	32.8	213T	\$2,931	43.8	215T	\$3,244
10	14.6	184T	\$2,813	29.2	213T	\$2,843	43.8	215T	\$3,244	58.3	254T	\$3,944
15	21.9	184T	\$2,964	43.8	215T	\$3,244	65.6	254T	\$4,217	87.5	256T	\$5,124
20	29.2	213T	\$3,415	58.3	254T	\$3,944	87.5	256T	\$5,124	116.7	286T	\$7,369
25	36.5	215T	\$4,096	72.9	256T	\$4,482	109.4	284T	\$6,632			
30	43.8	215T	\$5,017	87.5	256T	\$5,124	131.3	286T	\$8,106			
40	58.3	254T	\$5,128	116.7	286T	\$7,369						
50	72.9	256T	\$5,827									
60	87.5	256T	\$6,661									
75	109.4	284TS	\$7,001									

Available in 48, 56, 143T or 145T (140T flange mount only)

Blue shaded areas are Cast Iron Frames

Option	List Price			Multiplier Symbol E3	
	48-56	182-184	213-215	254-256	284-286
Hall Effect Sensor	\$ 150	N/A	N/A	N/A	N/A
HS35 Incremental Encoder (1024ppr with "Z" reference pulse) -OPTICAL	\$1,291	\$1,291	\$1,291	\$1,291	\$1,291
HS35 Incremental Encoder (1024ppr with "Z" reference pulse) -MAGNETIC	\$1,495	\$1,495	\$1,495	\$1,495	\$1,495
C-Face (with feet)	\$ 97	\$ 143	\$ 143	\$ 194	\$ 308
C-Face (footless)	\$ 97	\$ 287	\$ 287	\$ 388	\$ 617
Precision Balance	\$ 185	STD	STD	STD	STD
AEGIS SGR Shaft Voltage mitigation	\$ 92	\$ 116	\$ 140	\$ 187	\$ 234
IP54	\$ 75	STD	STD	STD	STD
IP55	\$ 135	\$ 289	\$ 470	\$ 492	\$ 509
IP56	N/A	\$ 637	\$1,238	\$1,259	\$1,291
Terminal block (not available on dual voltage motors)	\$ 175	STD	STD	STD	STD
Thermistors	N/A	\$ 206	\$ 206	\$ 206	\$ 206
Thermistor Control Module	N/A	\$ 663	\$ 663	\$ 663	\$ 663
Phase Insulation (not required for 115V)	\$ 83	STD	STD	STD	STD
Brake	Consult Factory				
Other options and accessories	Consult Factory				

SyMAX[®] Performance Data

Typical Motor Performance

Efficiency vs Speed

Permanent Magnet AC vs NEMA Premium Induction

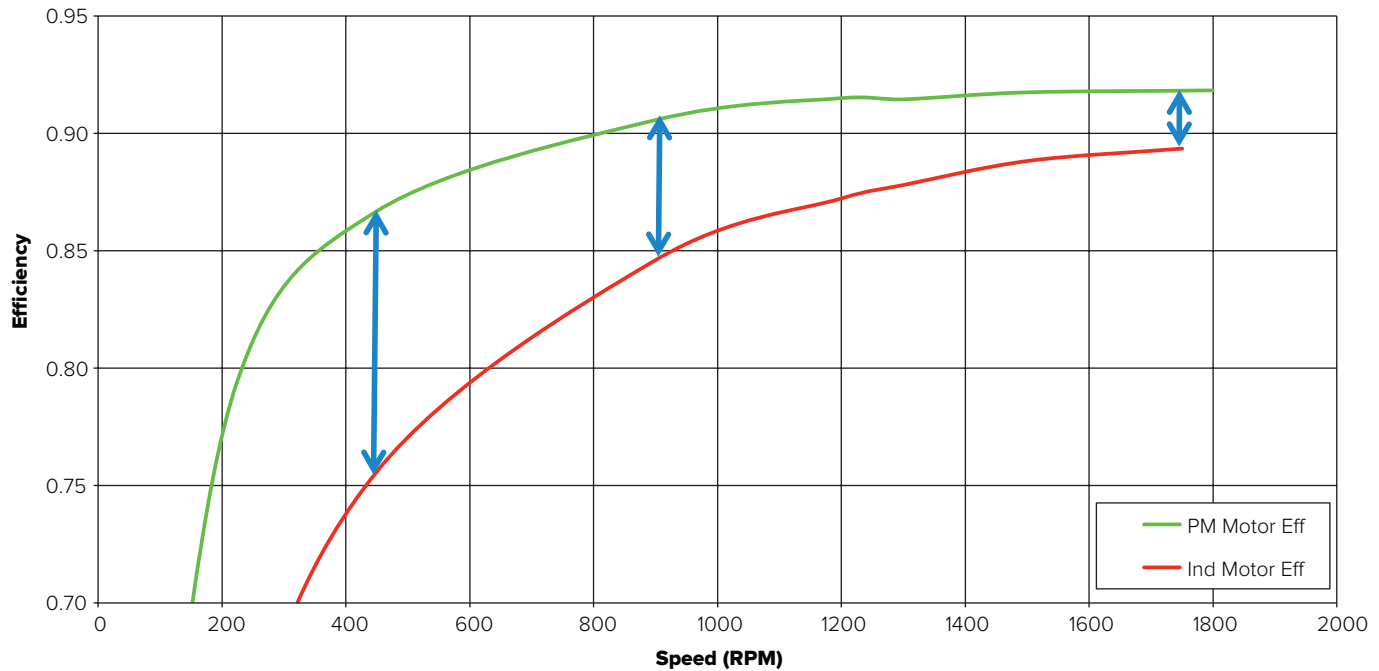

Standard Performance Data (contact factory for other base speeds)

1800 RPM (6-Pole; 90 Hz input) - DATA AT 460VAC

Rated HP	FL Torque (Lb-Ft)	NEMA Frame	IEC Frame	FLA (460V)	F.L. Effic.	Min Const Torque Speed	Max Const HP Speed	BEMF (L-L @ 1800)	Resis/Ph (ohms)	Ld (mH)	Lq (mH)	Lq:Ld ratio	Rotor Inertia (Lb-Ft ²)
1/2	1.46	56	80	0.9	83.5	90	2160	262	11.360	65.200	152.800	2.3	0.022
3/4	2.19	56	80	1.3	85.8	90	2160	284	6.280	50.000	106.800	2.1	0.032
1	2.92	56	80	1.8	85.3	90	2160	274	3.680	35.200	75.200	2.1	0.043
1 1/2	4.38	56	80	2.7	86.1	90	2160	274	1.880	19.840	46.000	2.3	0.064
2	5.83	56	80	3.2	86.5	90	2160	306	1.760	20.000	48.000	2.4	0.082

1800 RPM (10-Pole; 150 Hz input) - DATA AT 460VAC

Rated HP	FL Torque (Lb-Ft)	NEMA Frame	IEC Frame	FLA (460V)	F.L. Effic.	Min Const Torque Speed	Max Const HP Speed	BEMF (L-L @ 1800)	Resis/Ph (ohms)	Ld (mH)	Lq (mH)	Lq:Ld ratio	Rotor Inertia (Lb-Ft ²)
3	8.8	182T	112M	3.8	91.7	90	2160	403	1.690	34.600	44.100	1.3	0.19
5	14.6	184T	112L	6.4	91.7	90	2160	409	0.900	22.850	30.100	1.3	0.27
7 1/2	21.9	213T	132M	9.4	93.0	90	2160	403	0.400	10.500	12.900	1.2	0.54
10	29.2	215T	132L	11.8	93.6	90	2160	443	0.650	9.000	11.100	1.2	0.70

1800 RPM (8-Pole; 120 Hz input) - DATA AT 460VAC

Rated HP	FL Torque (Lb-Ft)	NEMA Frame	IEC Frame	FLA (460V)	F.L. Effic.	Min Const Torque Speed	Max Const HP Speed	BEMF (L-L @ 1800)	Resis/Ph (ohms)	Ld (mH)	Lq (mH)	Lq:Ld ratio	Rotor Inertia (Lb-Ft ²)
15	43.8	254T	160M	18.5	94.5	90	2160	404	0.225	10.170	16.730	1.6	3.9
20	58.4	256T	160L	22.9	95.0	90	2160	400	0.207	6.570	11.040	1.7	4.8
25	72.9	284T	180M	28.1	95.0	90	2160	404	0.100	6.050	9.760	1.6	5.7
30	87.5	286T	180L	33.7	95.4	90	2160	387	0.062	4.810	7.670	1.6	6.5
40	116.7	286T	180L	45.5	95.4	90	2160	395	0.060	4.420	6.970	1.6	7.2

NEMA Quick Reference Dimensional Chart

Typical C-Face Motor

Contact your Marathon Electric sales representative for "AB", "O", & "P" Dimensions

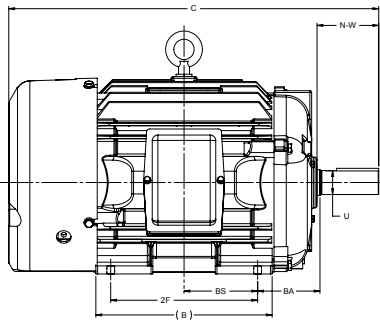

Typical Rigid Base Motor

Refer to your Marathon Electric catalog for "C" Dimensions

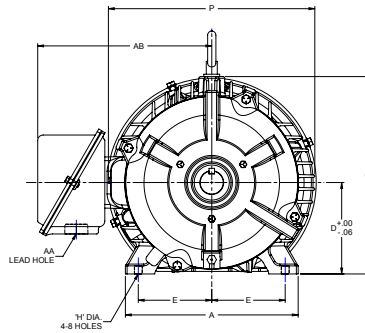

NEMA
C-Face
145-5TC
182-4TC
213-5TC
254-6TC

BA
Dimensions
2-3/4
3-1/2
4-1/4
4-3/4

Frame	D	E	2F	H	U	N-W	AA	AH	AJ	AK	BA	BB (MIN)	BD (MAX)	BF
48	3.00	2.12	2.75	.34 SLOT	.5000	1.50	1/2	1.89	3.750	3.000	2.50	.13	5.62	1/4-20
56	3.50	2.44	3.00	.34 SLOT	.6250	1.88	1/2	2.06	5.875	4.500	2.75	.13	6.50	3/8-16
56H	3.50	2.44	5.00	.34 SLOT	.6250	1.88	1/2	2.06	5.875	4.500	2.75	.13	6.50	3/8-16
143T	3.50	2.57	4.00	.34	.8750	2.25	3/4	2.12	5.875	4.500	2.25	.13	6.50	3/8-16
145T	3.50	2.75	5.00	.34	.8750	2.25	3/4	2.12	5.875	4.500	2.25	.13	6.50	3/8-16
182	4.50	3.75	4.50	.41	.8750	2.25	3/4	2.12	5.875	4.500	2.75	.13	6.50	3/8-16
184	4.50	3.75	5.50	.41	.8570	2.25	3/4	2.12	5.875	4.500	2.75	.13	6.50	3/8-16
182T	4.50	3.75	4.50	.41	1.125	2.75	3/4	2.62	7.250	8.500	2.75	.25	9.00	1/2-13
184T	4.50	3.75	5.50	.41	1.125	2.75	3/4	2.62	7.250	8.500	2.75	.25	9.00	1/2-13
213	5.25	4.25	5.50	.41	1.125	3.00	1	2.75	7.250	8.500	3.50	.25	9.00	1/2-13
215	5.25	4.25	7.00	.41	1.125	3.00	1	2.75	7.250	8.500	3.50	.25	9.00	1/2-13
213T	5.25	4.25	5.50	.41	1.375	3.38	1	3.12	7.250	8.500	3.50	.25	9.00	1/2-13
215T	5.25	4.25	7.00	.41	1.375	3.38	1	3.12	7.250	8.500	3.50	.25	9.00	1/2-13
254U	6.25	5.00	8.25	.53	1.375	3.75	1-1/4	3.50	7.250	8.500	4.25	.25	10.00	1/2-13
256U	6.25	5.00	10.00	.53	1.375	3.75	1-1/4	3.50	7.250	8.500	4.25	.25	10.00	1/2-13
254T	6.25	5.00	8.25	.53	1.625	4.00	1-1/4	3.75	7.250	8.500	4.25	.25	10.00	1/2-13
256T	6.25	5.00	10.00	.53	1.625	4.00	1-1/4	3.75	7.250	8.500	4.25	.25	10.00	1/2-13
284U	7.00	5.50	9.50	.53	1.625	4.88	1-1/2	4.62	9.00	10.500	4.75	.25	11.25	1/2-13
286U	7.00	5.50	11.00	.53	1.625	4.88	1-1/2	4.62	9.00	10.500	4.75	.25	11.25	1/2-13
284T	7.00	5.50	9.50	.53	1.875	4.62	1-1/2	4.38	9.00	10.500	4.75	.25	11.25	1/2-13
286T	7.00	5.50	11.00	.53	1.875	4.62	1-1/2	4.38	9.00	10.500	4.75	.25	11.25	1/2-13
284TS	7.00	5.50	9.50	.53	1.625	3.25	1-1/2	3.00	9.00	10.500	4.75	.25	11.25	1/2-13
286TS	7.00	5.50	11.0	.53	1.625	3.25	1-1/2	3.00	9.00	10.500	4.75	.25	11.25	1/2-13

Performance-Matched Drives for Use With SyMAX® Permanent Magnet AC Motors



SyMAX[®] Permanent Magnet AC Motors

Save Energy Every Time You Use Them

Looking for the next level of efficiency? SyMAX[®] PMAC motors deliver impressive energy savings by the elimination of rotor conductor losses, optimized fan design, precision-wound stator and variable speed operation. These Ultra Efficient[™] motors exceed European IE4 efficiency levels...5 years ahead of scheduled implementation, achieving efficiencies 25% over NEMA Premium[™]! The energy savings alone often pays for the motor in as little as one year. Additionally, the SyMAX[®] efficiency profile remains flatter than an equivalent induction motor as the speed and load declines, allowing the user to capture even greater energy savings when operated at the application's ideal speed.

Electric motors consume an estimated 25% of all electricity and up to 65% of all electrical energy consumed by industrials. Energy costs are projected to continue to increase in the future. A 1% gain in energy efficiency would reduce carbon emissions by an estimated 80 million tons per year. SyMAX[®] motors provide a very cost-effective way to reduce our "carbon footprint" and assure a cleaner environment.

It's estimated that the total lifetime cost of a typical electric motor consists of 2-3% purchase cost, 2-3% maintenance and up to 96% electric power. Electric utility rates worldwide are increasing, so energy cost will become an even more important consideration in the purchase of electric motors.

The higher power density of the SyMAX[®] motor provides even greater opportunities for energy savings due to its delivery of higher torque/amp.

Efficiency curves for AC induction motors tend to remain relatively flat from approximately 60% to 100% of rated load (torque), representing a little more than 75% of rated speed in a variable torque application, such as fans or pumps where the torque varies as the square of the speed.

As this chart illustrates, SyMAX[®] PMAC motors tend to exhibit a flatter efficiency curve down to lower loads. System efficiency gains are maximized by operating at the optimal speed (load). Therefore, the actual operating point is most often below "base speed". Note the greater efficiency gain at 50% load versus the base speed.

SyMAX[®] Motor Energy Payback Calculator

Based on 1800 RPM, Totally Enclosed

NEMA Premium AC Induction versus SyMAX "Ultra Efficient" Permanent Magnet AC

Cost / kWh	\$0.101						
Hours / Day	24						
Days / Year	365						
Calculation of Payback							
HP	NEMA Premium AC Induction			Ultra Efficient SyMAX			Payback
	Effic.	Price	Energy Cost	Effic.	Price	Energy Cost	
5	89.5%	\$ 550	\$ 3,669	91.7%	\$ 665	\$ 3,581	1.3
10	91.7%	\$ 812	\$ 7,162	93.6%	\$1,000	\$ 7,017	1.3
20	93.0%	\$1,300	\$14,124	95.0%	\$1,600	\$13,827	1.3
30	93.6%	\$1,799	\$21,050	95.4%	\$2,300	\$20,653	1.3

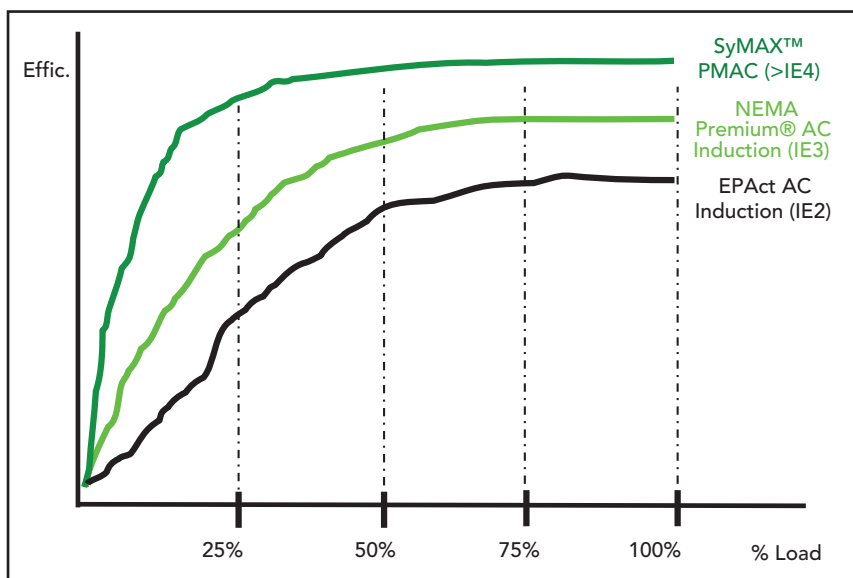

SyMAX[®] Commercial PMAC Motor Design

SyMAX[®] FHP Permanent Magnet AC motors are designed with powerful rare earth magnets embedded in the rotor. We kept the induction motor's "form factor" (mounting dimensions) precisely the same to ensure direct drop-in replacement capability.

Due to the elimination of rotor conductor losses, SyMAX[®] motors are inherently more efficient. With more of its electrical power converted to useful work, and less waste energy in the form of heat, SyMAX[®] operates much cooler than traditional NEMA Premium[®] induction motors, resulting in longer life.

In addition to their high efficiency and lower operating temperature, SyMAX[®] motors deliver more torque per unit of current, often resulting in the selection of a smaller drive size.

These characteristics, plus an impressive vibration and sound profile, low cogging torque and unmatched ingress protection (IP43), make SyMAX[®] the only real choice in NEMA permanent magnet AC motors available today.

SyMAX[®] PMAC performance

- "Ultra-Efficient[™]" - Significant energy savings over AC Induction
- High Power Factor
- Low vibration
- Sound levels exceed requirements in IEEE841 specification
- Low operating temperature
- Low cogging torque
- Optimized Back EMF
- Full torque at zero speed (Infinity:1)

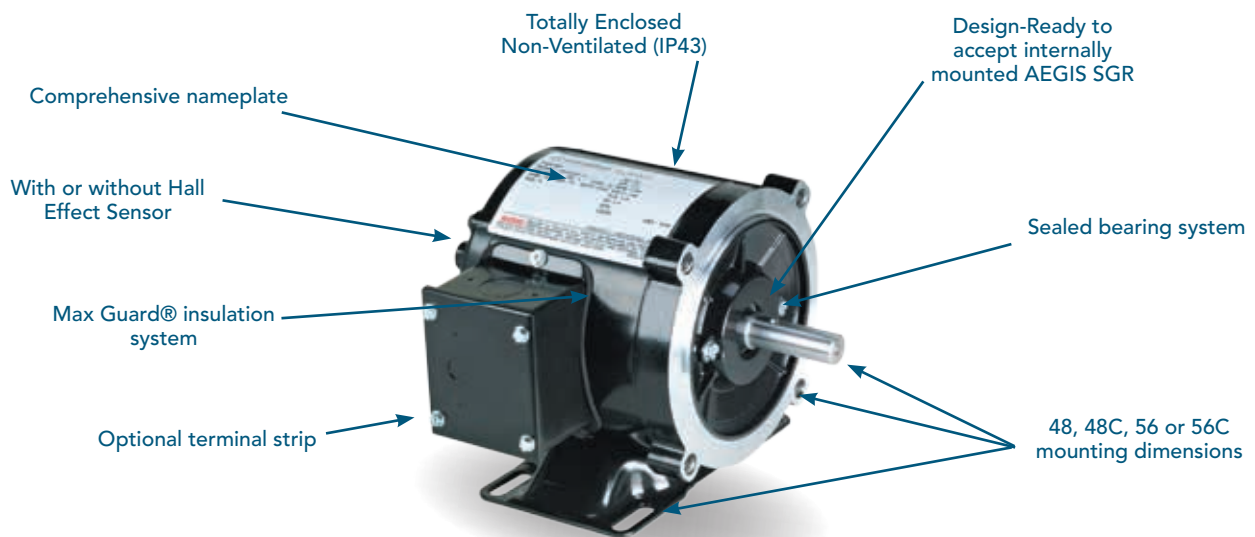

Feature

- Ultra High[™] efficiency
- Performance matched
- Reduced operating temperature
- IP43 ingress protection
- Anti-Cogging technology
- Normal form factor (NEMA mounting and dimensions)
- Optional hall effect sensor (constant torque loads)
- Wide speed range (up to 2000:1 constant torque)
- Max Guard[®] insulation system
- WorryFree[™] bearing system
- Design-Ready to accept internally mounted AEGIS[™] SGR
- Interior Permanent Magnet topology
- Omnimount[™]
- Meets or exceeds industry sound level requirements
- Low inertia rotor
- High torque per amp
- Trickle heating
- High power density (option)
- Direct Drive[™] (option)
- Comprehensive nameplate
- UL Recognized, CSA Certified
- CE Mark
- 3 year "bearing-to-bearing" warranty

Benefit

- Utility savings from day 1, minimize impact of increasing energy costs
- Maximum flexibility, easier drive selection
- Longer service life, more uptime, higher reliability, reduced maintenance
- Suitable for indoor or outdoor environments, longer service life
- Reduced noise, more efficient use of torque
- Direct mechanical retrofit into existing application
- Optimal performance for constant torque loads
- Optimal performance with open- and closed-loop drives
- Reduced insulation stresses due to dV/dT
- Reduced lubrication frequency, resulting in lower maintenance cost
- Higher reliability, longer service life, lower maintenance
- Accommodates higher speed operation, improved performance
- Accommodates horizontal, vertical shaft down & vertical shaft up mounting
- High user acceptance
- Highly responsive to accel/decel requirements
- Possible use of next lower drive size
- Reduces build up of condensation during off cycles or in cold ambient
- Accommodates smaller frame size, lower weight
- Allows reduction or elimination of mechanical power transmission equipment
- Provides all required parametric data for fast and easy drive set-up
- The only PMAC motor on the market today with agency recognition
- Certified for use in Europe, full compliance with IEC60034 and IEC60072
- Longest warranty for any PMAC motor on the market today

SyMAX[®] Industrial PMAC Motor Design

SyMAX[®] IHP Permanent Magnet AC motors are designed with powerful rare earth magnets embedded in the rotor. We kept the induction motor's "form factor" (physical envelope) precisely the same to ensure direct drop-in replacement capability.

Due to the elimination of rotor conductor losses, SyMAX[®] motors are inherently more efficient. With more of its electrical power converted to useful work, and less waste energy in the form of heat, SyMAX[®] operates much cooler than traditional NEMA Premium[®] induction motors, resulting in longer life.

In addition to their high efficiency and lower operating temperature, SyMAX[®] motors deliver more torque per unit of current, often resulting in the selection of a smaller drive size.

These characteristics, plus an impressive vibration and sound profile, low cogging torque and unmatched ingress protection (IP54), make SyMAX[®] the only real choice in NEMA and IEC permanent magnet AC motors available today."

SyMAX[®] PMAC performance

- Ultra-Efficient™ - Exceeds NEMA Premium[®], meets or exceeds IE4
- High Power Factor (on VFD power)
- Ultra-Precision balance to < 0.08 in/sec vibration
- Sound levels exceed requirements in IEEE841 specification
- Low operating temperature
- Concentrated winding stator reduces dV/dT stresses
- Low cogging torque
- Optimized Back EMF
- Full torque at zero speed (Infinity:1)

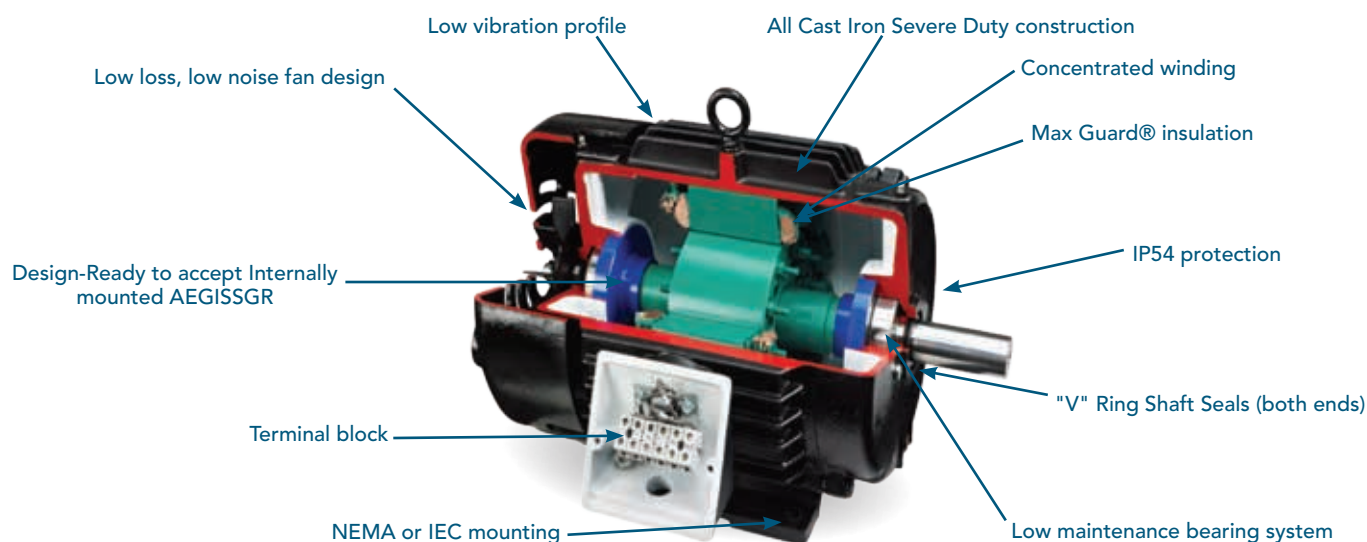

Feature

- Ultra High™ efficiency (20-25% fewer losses vs NEMA Premium)
- Performance matched
- Reduced operating temperature
- IP54 ingress protection
- Cast Iron construction
- Normal form factor (NEMA or IEC mounting and dimensions)
- Terminal block connections
- LowCog™ design
- Wide speed range (up to 2000:1 constant torque)
- Max Guard[®] insulation system
- WorryFree™ bearing system
- Design-Ready to accept internally mounted AEGIS™ SGR
- Interior Permanent Magnet topology
- Wide air gap
- Precision balanced to < 0.08 in/second vibrational velocity
- Omnimount™
- Meets or exceeds industry sound level requirements
- Low inertia rotor
- High torque per amp
- Trickle heating
- High power density (option)
- Direct Drive™ (option)
- Comprehensive nameplate
- UL Recognized, CSA Certified
- CE Mark
- 3 year "bearing-to-bearing" warranty

Benefit

- Utility savings from day 1, minimize impact of increasing energy costs
- Maximum flexibility, easier drive selection
- Longer service life, more uptime, higher reliability, reduced maintenance
- Suitable for the harshest environments, longer service life
- Reduced vibration, suitable for severe environments, quiet operation
- Direct mechanical retrofit into existing application
- Faster, easier, safer installation; reduction in required size
- Increased performance, quieter and smoother operation
- Optimal performance with open- and closed-loop drives
- Reduced insulation stresses due to dV/dT
- Reduced lubrication frequency, resulting in lower maintenance cost
- Higher reliability, longer service life, lower maintenance
- Accommodates higher speed operation, improved performance
- Enhanced protection from bearing currents
- Reduced vibration meets the most stringent industry standards
- Accommodates horizontal, vertical shaft down & vertical shaft up mounting
- High user acceptance
- Highly responsive to accel/decel requirements
- Possible use of next lower drive size
- Reduces build up of condensation during off cycles or in cold ambient
- Accommodates smaller frame size, lower weight
- Allows reduction or elimination of mechanical power transmission equipment
- Provides all required parametric data for fast and easy drive set-up
- The only PMAC motor on the market today with agency recognition
- Certified for use in Europe, full compliance with IEC60034 and IEC60072
- Longest warranty for any PMAC motor on the market today

Permanent Magnet Motor Terminology

Alignment Torque - Produced by the interaction of the magnetic fields produced by permanent magnets and winding currents, also called mutual torque.

Axial Flux - A magnetic field that travels in an axial direction across the air gap between the rotor and stator.

BLAC Motor - Brushless AC electric motor, also known as a permanent magnet synchronous motor (PMSM), is similar to a brushless DC electric motor in that the magnetic field of the rotor is supplied by the permanent magnets rather than by electromagnets.

BLDC Motor - Brushless DC is a synchronous electric motor powered by direct-current (DC) and having an electronic commutation system, rather than a mechanical commutator and brushes. A BLDC motor is described in terms such as torque constant and back EMF constant. In BLDC motors, current to torque and voltage to RPM are linear relationships.

Back EMF - The voltage generated when a permanent magnet motor is rotated. This voltage is proportional to motor speed and is present whether the motor winding(s) are energized or not.

Closed Loop - A broadly applied term relating to any system in which the output is measured and compared with the input. The output is then adjusted to reach the desired condition. In motion control, the term typically describes a system utilizing a velocity and/or position transducer to generate correction signals in relation to desired parameters.

Cogging (Cogging Torque) - A term used to describe non-uniform angular velocity. Cogging appears as jerkiness, especially at low speeds.

Commutation - The process of successively energizing and deenergizing motor phase windings in a way that produces useful torque.

Concentrated Winding - Electrical windings that are physically isolated from other phase windings.

Demagnetization Current - The current level at which the motor magnet flux (magnetic strength) deteriorates. This is an irreversible effect which will alter the motor characteristics and degrade performance. Also known as peak current.

Detent Position - Rotor position where there is zero torque.

Direct Drive™ Technology - Describes motors that transmit power to the application directly without the use of mechanical speed reduction (torque multiplication) devices such as gears, pulleys, chains or belts.

Distributed Winding - Electrical windings which are distributed and interlaced with other phase windings. Wound to simulate a sinusoidal wave.

Down Framing™ - The ability to increase the motor's power in a smaller frame size.

Dynamic Braking - A passive technique to stop a permanent magnet (brushed or brushless) motor. The motor windings are shorted together through a resistor which results in motor braking through an exponential decrease in speed.

ECM Motor - Electrically Commutated Motor (ECM) is a brushless motor which relies on the external power drive to perform the commutation of stationary copper winding on the stator. This changing stator field causes the permanent magnet rotor to rotate.

Eddy Current - Localized currents induced in an iron core by alternating magnetic flux. These currents translate into losses (heat).

Efficiency (Motor) - The ratio of mechanical output to electrical input. It represents the effectiveness with which the motor converts electrical energy into mechanical energy.

Efficiency (System) - The overall efficiency of the motor, controls, electric cables, drive train and driven equipment. This is determined by multiplying the individual component efficiencies together.

Encoder - A feedback device which converts mechanical motion into electronic signals. The most commonly used, rotary encoders, output digital pulses corresponding to incremental angular motion. A 1024 line (ppr) encoder produces 1024 pulses per revolution. An optical encoder consists of a glass or metal disk with alternating transparent and opaque stripes, detected by optical sensors to produce the digital outputs. Magnetic encoders operate similarly, except pulses are detected using principles of magnetism. Various output signals are available, including quadrature, sin/cos, SSI/Open Collector, and others. Absolute encoders provide greater position control, as each "pulse" is unique, allowing the user to detect "absolute" rotor position.

Field Weakening - Used in vector control whereby the motor currents must be increased before the respective peaks of the back EMFs appear. This is done by advancing the motor currents in phase relative to their back EMF. Voltage is "clamped" at the drive's maximum value and frequency continues to increase, thereby changing the V/Hz scheme of the drive, allowing motor operation above "base RPM".

Flux (Flux Density) - The magnetic "force" through a medium; a scalar quantity describing the net fluid passing through an area. Density describes the magnetic field fluid at a point in space; a special vector quantity.

Hall-Effect Sensor - Feedback device which is used in a brushless system to provide information for the amplifier to electronically commutate the motor. Uses a magnetized wheel and hall-effect sensors to generate the commutation signals.

Hysteresis - A property of a magnetic material where the flux density in a material is a function of the history of the fluid intensity across the material; produces energy loss in a material.

Inductance - An electrical property within the circuit where a change in the electric current through that circuit induces an electromotive force (EMF) that opposes the change in current.

Inertia - The property of an object to resist change in velocity unless acted upon by an outside force. Higher inertia objects require larger torques to accelerate and decelerate. Inertia is dependent upon the mass and shape of the object.

Interior Permanent Magnet (IPM) - A permanent magnet motor topology in which the magnets are buried within the (lamination) steel structure of the rotor. Advantages of IPM designs include greater flux concentration, higher structural strength, particularly in high speed applications, and greater ability to drive the motor over a wider speed range.

Magnetic Anisotropy - Directional dependence of a material's magnetic properties. A magnetically isotropic material has no preferential direction for its magnetic moment in zero field, while a magnetically anisotropic material will align its moment to an easy axis.

Magnetic Field - Magnetic fields surround magnetic materials and electric currents, and are detected by the force they exert on other magnetic materials and moving electric charge. The magnetic field at any given point is specified by both a *direction* and a *magnitude* (or strength).

Magnetomotive Force (MMF) - Any physical force that produces magnetic flux. In this context, the word "force" is used in a general sense of "work potential", and is analogous to, but distinct from mechanical force measured in newtons. The name came about because in magnetic currents it plays a role analogous to the role electromotive force (voltage) plays in electrical circuits.

Magnetic Saliency - The variation of the inductance at the motor terminal according to the rotor position. Also referred to as inductance saliency.

Mutual Torque - Produced by the interaction of the magnetic fields produced by permanent magnets and winding currents, also called alignment torque.

Neodymium Magnet - A type of rare earth magnet, made from an alloy of neodymium, iron and boron to form Nd₂Fe₁₄B tetragonal crystalline structure. This material is currently the strongest type of permanent magnet.

Open Loop - A system in which there is no feedback. Motor motion is expected to faithfully follow the input command.

Peak Torque (Tpk) - The maximum torque which a PM motor can deliver for short periods of time. Not to be confused with system peak torque which is often determined by amplifier peak current limitations where peak current is typically two times continuous current.

Permeability - A material property that describes how easily a magnetic field flows through the material, analogous to how conductivity describes how easily current flows through a material.

Permanent Magnet Synchronous Motor (PMSM) - An AC motor distinguished by a rotor spinning with coils passing magnets at the same rate as the alternating current and resulting magnetic field which drives it. Also referred to as a brushless AC and permanent magnet AC.

Power (horsepower, kilowatts) - The rate at which work is done. Power is a function of torque and speed.

Power Density - The ratio of power to mass (weight, size). A power dense design is said to deliver the same amount of power in a smaller package,

Formulas & Conversion Factors

greater power in the same sized package, or some combination of the two. Due to their lower losses and the more powerful magnetic field, permanent magnet motors using rare earth rotor magnets are typically more “power dense”, delivering high torque per unit of current.

Radial Flux - A magnetic field that travels in a radial direction across the air gap between the rotor and stator.

Reluctance - Magnetic reluctance is a concept used in the analysis of magnetic circuits. It is analogous to resistance in an electrical circuit, but rather than dissipating magnetic energy, it stores magnetic energy. In likeness to the way an electric field causes an electric current to follow the path of least resistance, a magnetic field causes magnetic flux to follow the path of least magnetic resistance.

Reluctance Torque - Produced by permanent magnets acting alone or by winding currents acting alone.

Repeatability - The degree to which a parameter such as position or velocity can be duplicated.

Resolver - An electromagnetic feedback device which converts angular shaft position into analog signals. These signals can be processed in various ways such as with an RDC to produce digital position information. There are two basic types of resolvers; transmitter and receiver. A transmitter-type is designed for rotary primary excitation and stator secondary outputs. Position is determined by the ratio of the sine output amplitude to cosine output amplitude. A receiver-type is designed for stator primary excitations and rotor secondary output. Position is determined by the phase shift between the rotor output signal and one of the primary excitation signals.

Root Mean Square (RMS) Torque - In an intermittent duty cycle application, the RMS Torque is equal to the value of steady state torque which would produce the equivalent motor heating over a period of time.

Saturation - A non-linear property of ferromagnetic material whereby it becomes increasingly difficult to force additional magnetic flux through the material as the flux level increases.

Sinusoidal Wave Form - When the back EMF is sinusoidal, the motor is referred to as a permanent magnet synchronous motor. See BLAC Motor.

Skew - The arrangement of laminations or magnets on a rotor or stator to provide a slight diagonal pattern of their slots with respect to the shaft. Skew is used to reduce electrical noise as it provides a smoother transition as the permanent magnet rotor rotates within the magnetic field of the stator windings.

Surface Permanent Magnet (SPM) - Permanent magnet motors that have magnets mounted on the rotor surface facing the air gap. Among other limitations, SPM motor designs are not ideal for high speed applications.

Torque - A measure of angular force which produces rotational motion. This force is defined by a linear force multiplied by a radius, e.g. lb-in. Torque is an important parameter of any motion control system.

Torque-to-Inertia Ratio - Defined as the motor's holding torque divided by the inertia of its rotor. The higher the ratio, the higher a motor's maximum acceleration capability will be.

Torque Constant - The rate at which torque increases with respect to current. The symbol K_t identifies the Torque Constant.

Torque Ripple - Torque variables that exist about a constant value.

Trapezoidal Wave Form - When the Back EMF is trapezoidal, the motor is referred to as a brushless DC Motor. See BLDC Motor.

Ultra Efficient™ - Defines a level of efficiency substantially higher than NEMA Premium. This efficiency level meets European IE4, which is defined as IE3 with 15% fewer losses.

Vector Control - A means to express motor quantities in terms of quadrature and direct components. In vector control, the instantaneous motor phase currents are processed by multiplication by a dq transformation matrix to produce I_q and I_d . The difference between these values and their respective desired values creates error signals that are used in control loops to drive the actual currents to the desired values.

Velocity - Velocity is the change in position as a function of time. Velocity has both a magnitude and sign.

Mechanical formulas:

$$\text{Torque (lb-ft)} = \frac{\text{HP} \times 5,250}{\text{RPM}} \quad \text{Torque (in-lb)} = \frac{\text{HP} \times 63,000}{\text{RPM}}$$

$$\text{HP} = \frac{\text{Torque (lb-ft)} \times \text{RPM}}{5,250} \quad \text{HP} = \frac{\text{Torque (in-lb)} \times \text{RPM}}{63,000}$$

$$\text{Synchronous RPM} = \frac{120 \times \text{Frequency}}{\# \text{ Poles}}$$

Electrical formulas:

$$\text{Ohms} = \frac{\text{Volts}}{\text{Amperes}} \quad (R = E/I)$$

$$\text{Amperes} = \frac{\text{Volts}}{\text{Ohms}} \quad (I = E/R)$$

$$\text{Volts} = \text{Amperes} \times \text{Ohms} (E = IR)$$

Conversion factors:

$$\text{Newton-Meters (NM)} = 1.3558 \times \text{Lb-Ft}$$

$$\text{Pound-Feet (Lb-Ft)} = .7376 \times \text{Newton-Meters}$$

$$\text{Horsepower} = 746 \text{ watts (0.746 kW)}$$

$$\text{Kilowatts (kW)} = 1.341 \times \text{Horsepower}$$

$$\text{Temperature (C)} = 5/9 \times (F - 32)$$

$$\text{Temperature (F)} = (9/5 \times C) + 32$$

SyMAX Motor Safety Concerns

Important Information - Please Read Carefully

Excerpt from Installation & Operations Manual, Form 5968M:

Before installing, using, or servicing this product, carefully read and fully understand the instructions including all warnings, cautions, & safety notice statements. To reduce risk of personal injury, death and/or property damage, follow all instructions for proper motor installation, operation and maintenance.

Although you should read and follow these instructions, they are not intended as a complete listing of all details for installation, operation, and maintenance. If you have any questions concerning any of the procedures, or if you have a safety concern not covered by the instructions, STOP, and contact the motor manufacturer.

⚠ WARNING: ELECTRICAL SHOCK HAZARD: Electrical connections shall be made by a qualified electrician in accordance with all applicable codes, ordinances and sound practices. Failure to follow these instructions could result in serious personal injury, death and/or property damage. Only qualified personnel who are familiar with the applicable National Code (USA = NEC) and local codes should install or repair electrical motors and their accessories.

⚠ WARNING: ELECTRICAL HAZARD: Failure to connect motor and variable frequency drive in accordance with the drive manufacturer's documentation may result in serious injury, death, and/or property damage.

⚠ WARNING: ELECTRICAL LIVE CIRCUIT HAZARD: Do not touch electrically live parts. Disconnect, lockout and tag input power supply before installing or servicing motor (includes accessory devices). Use a voltmeter to verify that power is off before contacting conductors.

⚠ WARNING: ELECTRICAL SHOCK HAZARD: Shaft rotation produces voltage in PM motors even when motor is disconnected from power source. Do not open terminal box or touch unprotected terminals while the motor shaft is rotating. Failure to do so may cause serious injury or death to personnel.

⚠ WARNING: ELECTRICAL HAZARD: Shaft rotation produces voltage in PM motors even when motor is disconnected from power source. Do not operate the motor or allow equipment to back drive the motor above the maximum RPM listed on the motor nameplate. Failure to do so may cause serious injury or death to personnel or damage the motor or system equipment.

⚠ WARNING: ELECTRICAL GROUNDING HAZARD: Failure to properly ground motors, per the National Electrical Code (NEC) Article 430 and local codes may cause serious injury or death to personnel. For general information on grounding refer to NEC Article 250. (Also see "Ground Connections section 3.4.4").

⚠ WARNING: MAGNETIC FIELD HAZARD: Permanent magnet motor rotors, when removed from the stator, expose surrounding personnel and equipment to powerful magnetic fields which may cause serious health hazards to persons with pacemakers, hearing aids, or other implanted electronic medical devices and may impact other electronic devices such as mobile phones, credit cards, etc.

NOTICE: MOTOR NOT SUITED FOR OPERATION ON LINE POWER: Permanent magnet (PM) motors can only be operated by a PM motor compatible VFD (Variable Frequency Drive). Connecting directly to line power may result in motor damage.

1.2 MECHANICAL SAFETY

⚠ WARNING: LOOSE PARTS HAZARD: Before starting the motor, remove all unused shaft keys and loose rotating parts to prevent them from flying off. Failure to follow these instructions could result in serious personal injury, death and/or property damage.

⚠ WARNING: ROTATING PARTS HAZARD: Keep extremities, hair, jewelry and clothing away from moving parts. Failure to follow these instructions could result in serious personal injury, death and/or property damage. See section 3.3.7.

⚠ WARNING: DO NOT DISASSEMBLE: Due to powerful magnetic fields, disassembly and assembly of permanent magnet motors should only be performed by the manufacturer or specialized personnel authorized by the manufacturer. Only qualified personnel who are familiar with the applicable national codes, local codes and sound practices should install or repair electric motors and their accessories. See the Magnetic Field Hazard in section 1.1.

⚠ WARNING: HAZARDOUS LOCATIONS: The NEC and the local authority having jurisdiction must be consulted concerning the installation and suitability of motors for use in Hazardous Locations, in accordance with NEC Article 500. The local authority having jurisdiction must make the final determination of what type of motor is required. The application and operation is beyond the control of the motor manufacturer. Failure to do so may cause serious injury or death to personnel.

MPN411 Terms and Conditions of Sale

REGAL BELOIT CORPORATION ELECTRICAL GROUP TERMS AND CONDITIONS OF SALE. ALL QUOTATIONS ARE MADE AND ALL ORDERS ARE ACCEPTED BY RETAIL BELOIT CORPORATION ELECTRICAL GROUP SUBJECT ONLY TO THESE TERMS AND CONDITIONS. THROUGHOUT THIS DOCUMENT, REGAL BELOIT CORPORATION ELECTRICAL GROUP SHALL BE REFERRED TO AS SELLER.

1. MODIFICATIONS OF SALES TERMS: Any Terms and Conditions contained in any purchase order or other form of communication from Seller's customers which are additional to or different from these Terms and Conditions shall be deemed rejected by Seller unless expressly accepted in writing by Seller. In general, no modification, amendment, waiver or other change of any of these Terms and Conditions and those contained on the reverse side hereof and/or in attachments hereto ("Terms and Conditions"), or of any of Seller's rights or remedies thereunder, shall be binding on Seller unless expressly accepted in writing by Seller's authorized officers. No course of dealing, usage of trade or course of performance shall be relevant to explain or supplement any of these Terms and Conditions. In case of conflict between the Terms and Conditions printed on this page and those contained on the face side or in attachments hereto, the latter shall control. If any document issued by any party hereto is sent by facsimile or another form of electronic document transmission, the parties hereto agree that (a) the copy of any such document printed on the facsimile machine or printer of the recipient thereof is a counter part original copy thereof and is a "writing", (b) delivery of any such document to the recipient thereof by facsimile or such other form of electronic document transmission is authorized by the recipient thereof and is legally sufficient for all purposes as if delivered by United States mail, (c) the typewritten name of an authorized agent of the party sending such document on any such document is sufficient as a signature thereon on behalf of such party and the intent of such signature is to authenticate the writing, and (d) an electronically stored and reproduced copy of any such document shall be deemed to be legally sufficient evidence of the terms of such document for all purposes.

2. ACCEPTANCE OF ORDERS: Acceptance by Seller of Buyer's purchase order(s) is expressly conditioned upon Buyer's assent to these Terms and Conditions. Buyer will be deemed to have assented to such Terms and Conditions unless Seller receives written notice of any objections within fifteen (15) days after Buyer's receipt of this form and in all events prior to any delivery or other performance by Seller of Buyer's order.

3. QUOTATIONS: Quotations by Seller shall be deemed to be offers by Seller to sell the Goods described therein subject to these Terms and Conditions, and acceptance of such offers is expressly limited to acceptance by Buyer of all of these Terms and Conditions within thirty (30) days from the date of the quotation. Purchase orders submitted by Buyer for the Goods quoted by Seller shall be subject to and will be deemed to constitute acceptance of these Terms and Conditions. All purchase orders will be subject to approval by Seller.

4. PRICES; PRICE CHANGES: All prices are net F.O.B. shipping point and are subject to change without notice. In the event of a change in Seller's prices, the price for Goods unshipped will be the price in effect on the date of shipment. If Seller's quoted price was based upon delivery to and acceptance by Buyer of a specified quantity of Goods, such price shall be subject to adjustment if Buyer does not accept the quantity at the times specified in Seller's quotation, and Buyer will be invoiced at Seller's standard price without quantity discounts, if any, for the quantity of Goods actually accepted by Buyer.

5. TAXES: In addition to any prices, Buyer shall pay the amount of any present or future manufacturer's tax, retailer's occupation tax, use tax, sales tax, excise tax, duty, custom, inspection or testing fee, or any other tax, fee or charge of any nature whatsoever imposed by any governmental authority, on or measured by the transaction between Seller and Buyer. In the event Seller is required to pay any such tax, fee or charge, Buyer shall reimburse Seller thereof; or, in lieu of such payment, Buyer shall provide Seller at the time the order is submitted with an exemption certificate or other document acceptable to the authority imposing such tax, fee or charge.

6. TERMS OF PAYMENT: All orders are subject to the approval of Seller. Terms of payment are cash in full no later than thirty (30) days from date of shipment, without discount. If, during the period of performance of an order, the financial condition of Buyer is determined by Seller not to justify the terms of payment specified, Seller may demand full or partial payment in advance before proceeding with the work, or satisfactory security or guarantees that invoices will be promptly paid when due, or, at its option without prejudice to other lawful remedies, may defer delivery or cancel this contract. If delivery is deferred, the Goods may be stored as provided in Section 9 hereof and Seller may submit a new estimate of cost for completion based on prevailing conditions. If Buyer defaults in any payment when due, or in the event any voluntary or involuntary bankruptcy or insolvency proceedings involving Buyer are initiated by or against Buyer, then the whole contract price shall immediately become due and payable upon demand, or Seller, at its option without prejudice to its other lawful remedies, may defer delivery or cancel this contract. Prorata payments shall become due as shipments are made. If shipments are delayed by the Buyer for any cause, payments shall become due from the date on which Seller is prepared to make shipment and storage shall

be the Buyer's risk and expense as provided in Section 9 hereof. If manufacture is delayed by the Buyer for any cause, a partial payment based upon the proportion of the order completed shall become due from the date on which Seller is notified of the delay.

7. DELIVERY; RISK OF LOSS: All sales are F.O.B. Seller's plant or other point of shipment designated by Seller. Shipping dates are estimates only which are not guaranteed and are based upon prompt receipt from Buyer of all necessary shipping and other information. Seller reserves the right to make delivery in installments, all installments to be separately invoiced and paid for by Buyer when due per invoice, without regard to subsequent deliveries. Delivery of Goods to a commercial carrier at Seller's plant or other loading point shall constitute delivery to Buyer, and any risk of loss and further cost and responsibility thereafter for claims, delivery, loss or damage, including, if applicable, placement and storage, shall be borne by Buyer. When Goods are delivered by Seller's truck, unloading at Buyer's dock shall constitute delivery to Buyer. Claims for shortages or other errors in delivery must be made in writing to Seller within ten (10) days after receipt of shipment and failure to give such notice shall constitute unqualified acceptance and a waiver of all such claims by Buyer. Claims for loss or damage to Goods in transit by common carrier must be made to the carrier and not to Seller. Freight and handling charges by Seller may not reflect actual freight charges prepaid to the carrier by Seller due to incentive discounts earned by Seller based upon Seller's aggregate volume of freight tendered to a carrier or when a carrier must be used which charges a rate which is different than the rate upon which Seller's freight and handling charges were based. When shipments are delivered in Seller's private trucks Buyer will be charged an amount approximating the prevailing common carrier rate.

8. EXCUSABLE DELAYS; FORCE MAJEURE: Seller shall not be liable for any ordinary, incidental, or consequential loss or damage as a result of Seller's delay in or failure of delivery or installation due to (i) any cause beyond Seller's reasonable control, (ii) an act of God, act of the Buyer, embargo or other government act, authority, regulation or request, fire, theft, accident, strike, slowdown or other labor disturbance, war, riot, delay in transportation, or (iii) inability to obtain necessary labor, materials, components, or facilities. Should any of the aforementioned events of force majeure occur, Seller, at its option, may cancel Buyer's order with respect to any undelivered Goods or extend the delivery date for a period equal to the time lost because of delay. Notice of such election shall be given promptly to Buyer. In the event Seller elects to so cancel the order, Seller shall be released of and from all liability for failure to deliver the Goods, including, but not limited to, any and all claims on behalf of Buyer for lost profits, or any other claim of any nature which Buyer might have. If shipping or progress of the work is delayed or interrupted by Buyer, directly or indirectly, Buyer shall pay Seller for all additional charges resulting there from.

9. STORAGE: If the Goods are not shipped within thirty (30) days after notification has been made to Buyer that it is ready for shipping, for any reason beyond Seller's control, including Buyer's failure to give shipping instructions, Seller may store the Goods at Buyer's risk and expense in a warehouse or on Seller's premises, and Buyer shall pay all handling, transportation and storage costs at the prevailing commercial rates promptly following Seller's submission of invoices for such costs.

10. WARRANTIES TO DISTRIBUTORS AND INDUSTRIAL OR COMMERCIAL CUSTOMERS: This warranty is extended only to Seller's distributors and industrial or commercial customers and does not apply to consumer purchasers. Warranty Period - Motors (a) The Seller warrants motors manufactured by or for it to be free from defects in materials and workmanship and to conform to its written specifications for a period of twelve (12) months from date of first use or eighteen (18) months from date of manufacture, whichever period shall expire first. Warranty Period - Generators (a) The Seller warrants standby generators manufactured by or for it to be free from defects in materials and workmanship and to conform to its written specifications for a period of twelve (12) months from date of startup or eighteen (18) months from date of shipment, whichever period shall expire first. Certain Electrical Group Goods are warranted for different periods of time under specific conditions. Buyer must consult the current product catalog or internet site to confirm this warranty period. Warranty Remedies- If, prior to expiration of the foregoing applicable warranty period, any of such Goods shall be proved to Seller's satisfaction to be defective or nonconforming, Seller will repair or replace such defective Goods or components thereof, F.O.B. Seller's plant or other destination designated by Seller, or will refund or provide Buyer with a credit in the amount of the purchase price paid therefor by Buyer, at Seller's sole option. Buyer's exclusive remedy and Seller's sole obligation under this warranty shall be limited to such repair or replacement, F.O.B. Seller's plant or other destination designated by Seller, or refund or credit by Seller, and shall be conditioned upon Seller's receiving written notice of any defect within a reasonable period of time (but in no event more than sixty (60) days after it was discovered or by reasonable care should have been discovered. In no event shall Seller's liability for such defective or nonconforming Goods exceed the purchase price paid by

Buyer therefor. Exclusions- This warranty does not: (i) cover shipping expenses to and from Seller's factory or other destination designated by Seller for repair or replacement of defective Goods or any tax, duty, custom, inspection or testing fee, or any other charge of any nature related thereto, nor does it cover the costs of disassembling or removing defective Goods or reassembling, reinstalling, or testing repaired or replaced Goods or finishing the reinstallation thereof; (ii) apply and shall be void with respect to Goods operated in excess of rated capacity or otherwise not in accordance with installation, maintenance, or operating instructions or requirements, to Goods repaired or altered by others than Seller or Seller's authorized service agencies, or to Goods which were subjected to abuse, negligence, misuse, misapplication, accident, damages by circumstances beyond Seller's control, to improper installation (if by others than Seller), operation, maintenance or storage, or to other than normal use or service; and (iii) apply to equipment or components not manufactured by or for Seller. With respect to Goods or components not manufactured by Seller, Seller's warranty obligations shall in all respects conform and be limited to the warranty actually extended to Seller by its suppliers, but in no event shall Seller's obligations be greater than those provided under Seller's warranty set forth in this Section 10. THE FOREGOING WARRANTIES ARE IN LIEU OF ALL OTHER EXPRESS AND IMPLIED WARRANTIES (EXCEPT TITLE), INCLUDING, WITHOUT LIMITATION, THE IMPLIED WARRANTIES OF MERCHANTABILITY AND FITNESS FOR A PARTICULAR PURPOSE. NO EMPLOYEE, REPRESENTATIVE, OR AGENT OF SELLER OTHER THAN AN OFFICER OF SELLER IS AUTHORIZED TO ALTER OR MODIFY ANY PROVISION OF THIS SECTION 10 OR TO MAKE ANY GUARANTEE, WARRANTY, OR REPRESENTATION, EXPRESS OR IMPLIED, ORALLY OR IN WRITING, WHICH IS CONTRARY TO THE FOREGOING. Any description of the Goods, whether in writing or made orally by Seller or Seller's agents, specifications, samples, models, bulletins, drawings, diagrams, engineering sheets or similar materials used in connection with Buyer's order are for the sole purpose of identifying the Goods and shall not be construed as an express warranty. Any suggestions by Seller or Seller's agents regarding use, application or suitability of the Goods shall not be construed as an express warranty unless confirmed to be such in writing by Seller's authorized officer.

11. LIMITATIONS OF LIABILITY; CONSEQUENTIAL DAMAGES: Nuclear Use Disclaimer- Goods sold by Seller are not intended for use in connection with any nuclear facility or activity. If so used, Seller disclaims all liability for any nuclear damage, injury or contamination, and Buyer shall indemnify and hold Seller, its officers, agents, employees, successors, assigns and customers harmless from and against any and all losses, damages or expenses of whatever form or nature (including attorneys' fees and other costs of defending any action) which they or any of them may sustain or incur, whether as a result of breach of contract, warranty, tort (including negligence) or otherwise, by reason of such use. Consequential Damage Disclaimer- Seller's liability with respect to Goods proved to its satisfaction to be defective within the warranty period shall be limited to repair, replacement or refund as provided in Section 10 hereof, and in no event shall Seller's liability exceed the purchase price of the Goods involved. Seller shall not be subject to any obligations or liabilities, whether arising out of breach of contract, warranty, tort (including negligence) or other theories of law, with respect to Goods sold or services rendered by Seller, or any undertakings, acts or omissions relating thereto. Without limiting the generality of the foregoing, Seller specifically disclaims any liability for property or personal injury damages, penalties, special or punitive damages, damages for lost profits or revenues, loss of use of Goods or any associated Goods, cost of capital, cost of substitute products, facilities or services, downtime, shutdown, or slowdown costs, or for any other types of economic loss, and for claims of Buyer's customers for any such damages. SELLER SHALL NOT BE LIABLE FOR AND DISCLAIMS ALL CONSEQUENTIAL, INCIDENTAL AND CONTINGENT DAMAGES WHATSOEVER. EVEN IF THE REPAIR OR REPLACEMENT REMEDY SHALL BE DEEMED TO HAVE FAILED OF ITS ESSENTIAL PURPOSE UNDER SECTION 2-719 OF THE UNIFORM COMMERCIAL CODE, SELLER SHALL HAVE NO LIABILITY TO BUYER FOR CONSEQUENTIAL DAMAGES, SUCH AS LOST PROFITS, LOST REVENUE, DAMAGE TO OTHER GOODS OR LIABILITY OR INJURY TO A THIRD PARTY.

12. INDEMNIFICATION BY BUYER: Buyer shall indemnify, hold harmless, and defend Seller and Seller's employees and agents from and against any and all damages, liability, claims, losses, and expenses (including reasonable attorneys' fees, court costs, and out-of-pocket expenses) arising out of or resulting in any way from claims by customers of Buyer or third parties against Seller alleging a breach of contract or warranty by Seller to the extent that such damages, liability, claims, losses, and expenses which may be payable by Seller to Buyer pursuant to and as limited by Seller's warranty and damage obligations as contained in Sections 10 and 11 hereof so as to effectively limit Seller's obligations to customers of Buyer or third parties to those set forth in Sections 10 and 11 hereof.

13. PATENT INDEMNIFICATION: Seller will, at its own expense, defend or settle any suits that may be instituted against Buyer for alleged infringement by the Goods of any United States patent, provided that: (a) such alleged infringements consist of the use of the Goods for any of the purposes for which such Goods were sold; (b) Buyer shall have made all payments for such Goods then due hereunder; (c) Buyer shall give Seller immediate notice in writing of any such suit and transmit to Seller immediately upon receipt of all processes

and papers served upon Buyer; and (d) Buyer shall permit Seller through its counsel, either in the name of Buyer or in the name of Seller, to defend such suit(s) and give all needed information, assistance and authority to enable Seller to do so. In case of a final award of damages in any such suit, Seller will pay such award but will not be responsible for any compromise or settlement made without its written consent. In case the Goods itself is in such suit held to infringe any valid patent issued in the United States and its use enjoined, or in the event of a settlement or compromise approved by Seller which shall preclude future use of the Goods sold to Buyer hereunder, Seller shall, at its own expense and at its sole option, either: (a) procure rights to continue using such Goods; (b) modify the Goods to render it non-infringing; (c) replace the Goods with non-infringing Goods; or (d) refund the purchase price paid by Buyer for the Goods after return of the Goods to Seller. Notwithstanding the foregoing, Seller shall not be held responsible for infringements of combination or process patents covering the use of Goods in combination with other Goods or materials not furnished by Seller. The foregoing states the entire liability of Seller for patent infringement, and IN NO EVENT SHALL SELLER BE LIABLE FOR CONSEQUENTIAL OR INCIDENTAL DAMAGES ATTRIBUTABLE TO AN INFRINGEMENT nor for infringement based on the use of the Goods for a purpose other than that for which sold by Seller. As to any Goods furnished by Seller to Buyer manufactured in accordance with designs proposed or furnished by Buyer or any claim of contributory infringement resulting from the use or resale by Buyer of Goods sold hereunder, Buyer shall indemnify Seller for any award made against Seller or settlement by Seller for any patent, trademark or copyright infringements including attorneys' fees and defense costs.

14. SECURITY AGREEMENT AND FINANCING STATEMENTS: To secure payment of the purchase price and of all monies which may be due hereunder,

and performance of all of Buyer's obligations hereunder, Buyer hereby grants to Seller a security interest in all Goods sold by Seller, and agrees to execute such other Security Agreements and Financing Statements as Seller may reasonably request.

15. INSURANCE: Until payment in full of the purchase price, Buyer shall maintain insurance covering all Goods sold by Seller to Buyer in such amounts and against such risks as is customary by companies engaged in the same or similar business and similarly located, and shall, upon Seller's request, furnish evidence of such insurance satisfactory to Seller.

16. DRAWINGS; OTHER DESIGN DATA: All specifications, drawings, designs, data, information, ideas, methods, tools, gages, dies, fixtures, patterns and/or inventions made, conceived, developed or acquired by Seller in connection with procuring and/or executing Buyer's order will vest in and inure to Seller's sole benefit notwithstanding any changes therefor which may have been or may be imposed by Seller. Buyer shall not give, loan, exhibit, sell or transfer to any person not then employed by Buyer and authorized to receive such information, or to any organization or entity, any drawing, photograph or specification furnished by Seller or reproduction thereof which may enable such person, organization or entity to furnish similar Goods or parts therefor.

17. RETURN OF GOODS: No Goods or part shall be returned to Seller without written authorization and shipping instructions first having been obtained from Seller.

18. ASSIGNMENT AND SUBCONTRACTING: None of the Buyer's rights under any order shall be assigned by the Buyer to any other person, whether by operation of law or otherwise, without Seller's prior written approval. Seller may,

Frequently Asked Questions

Q: What are the primary benefits of PMAC motor versus AC Induction?

A: Permanent Magnet AC motors are inherently more efficient due to elimination of rotor conductor losses, lower resistance winding and "flatter" efficiency curve. Due to their synchronous operation, PMAC motors offer more precise speed control. PMAC motors provide higher power density due to the higher magnetic flux as compared with induction machines. Finally, Permanent Magnet motors generally operate cooler, resulting in longer bearing and insulation life.

Q: What are some of the major differences in performance between AC Induction and PMAC?

A: The most obvious performance difference is that a PMAC motor rotates at the same speed as the magnetic field produced by the stator windings; i.e. it is a synchronous machine. If the field is "rotating" at 1800 rpm, the rotor turns at the same speed. An induction motor, on the other hand, is considered an asynchronous machine, as its rotational speed is slightly slower than the magnetic field's "speed". An asynchronous motor is said to have "slip" (the difference between the motor's physical speed of, say, 1750 rpm, and its stator's magnetic speed of 1800 rpm) and cannot produce torque without this difference in speed, as the rotor is constantly trying to "catch up" with the magnetic field. The synchronization of PMAC results in improved efficiency, better dynamic performance and more precise speed control...a major benefit in positioning applications.

Q: Are SyMAX® motors suitable for Variable or Constant Torque applications?

A: Yes. The same motor can be used in either mode. The VFD and application parameters will dictate to the motor how much torque to produce at any given speed. The flexible design makes SyMAX® the logical choice when variable speed operation and ultra-high motor efficiency are key customer needs.

Q: What is "cogging torque", and is this an important consideration in selecting a PMAC motor?

A: The most basic source of cogging torque is the interaction or attraction of the permanent magnets and the steel structure of the stator as the motor rotates. These attractions and overcoming them prevent the rotor from turning smoothly. Another source is the interaction of the rotor magnets and the stator winding when it is energized, due to harmonics. Cogging is often an undesirable feature, causing noise, vibration and non-uniform rotation, so during product development, minimizing this effect was a design "CTQ" (Critical To Quality). As a result, SyMAX® motors have extremely low cogging torque, resulting in smoother operation at all speeds, virtually eliminating torque and speed "ripple".

Q: Are permanent magnets subject to "demagnetization"?

A: High current or high operating temperatures can cause magnets to lose their magnetic properties. The drive reduces the risk of high current "demag", as these devices are equipped with over-current protection. The motor design minimizes the possibility of excessive temperatures causing magnet failure, due to the selection of high temperature magnets, incorporation of thermostats and low operating temperature of the motor. Permanent magnets, once demagnetized, cannot recover, even if the current and/or temperatures return to normal levels.

Q: Can PMAC motors be operated without a drive?

A: No. All commercially available true permanent magnet motors require a variable frequency drive to operate.

without the necessity of obtaining Buyer's prior written consent, subcontract the production of all or any portion of the Goods.

19. CANCELLATION: No order submitted to Seller may be cancelled by Buyer without the prior written consent of Seller, which consent will at all times be conditioned on Buyer's agreement to pay Seller's cancellation charge. For finished Goods which in Seller's judgement is readily resalable to others, the cancellation charge shall be 15% of the invoice price of the Goods. For all other cancellations, the cancellation charge shall amount to all cost and expenses incurred by Seller and arising out of or in connection with Buyer's order, net of recoverability, but in no event less than 10% of the invoice price of the Goods or more than the invoice price.

20. GENERAL: Governing law- These Terms and Conditions, and the contract of sale between Seller and Buyer, shall be governed by and construed in accordance with the laws of the State of Wisconsin. Seller and Buyer hereby agree that any legal action deemed necessary by either party hereto shall be brought in the Circuit Court in and for Seller County, Wisconsin and hereby consent to the personal jurisdiction of such court in any such action over the parties hereto. The rights and obligations of Seller and Buyer shall not be governed by the provisions of the United Nations Convention on Contracts for the Internal Sale of Goods. Attorneys' Fees- Buyer agrees to pay all of Seller's costs and expenses of collection and related litigation, including but not limited to attorneys' fees and costs. Severability- The invalidity, in whole or in part, of any of the provisions of these Terms and Conditions, shall not affect the enforceability of any of the other provisions thereof. Applicability- The Terms and Conditions as stated herein are applicable as of the date of this printing and until such time as changed by Seller.

Resale of Goods

In the event of the resale of any of the goods, in whatever form, Resellers/ Buyers will include the following language in a conspicuous place and in a conspicuous manner in a written agreement covering such sale:

The manufacturer makes no warranty or representations, express or implied, by operation of law or otherwise, as to the merchantability or fitness for a particular purpose of the goods sold hereunder. Buyer acknowledges that it alone has determined that the goods purchased hereunder will suitably meet the requirements of their intended use. In no event will the manufacturer be liable for consequential, incidental or other damages. Even if the repair or replacement remedy shall be deemed to have failed of its essential purpose under Section 2-719 of the Uniform Commercial Code, the manufacturer shall have no liability to Buyer for consequential damages.

Resellers/Buyers agree to also include this entire document including the warnings and cautions above in a conspicuous place and in a conspicuous manner in writing to instruct users on the safe usage of the product.

This information should be read together with all other printed information supplied by Marathon Electric. For more information contact: Marathon Electric, Regal Beloit Manufacturing Corporation, 100 E. Randolph St., Wausau, WI 54401. Phone: 715-675-3311 or Fax: 715-675-8030.

Q: What is "power density", and how does it relate to PMAC motors?

A: Power density is simply the ratio of output power or horsepower to physical size or volume of the motor. There are many factors such as material characteristics and temperature constraints that limit how much power a machine can deliver of a certain size. Different topologies and machine configurations address these limitations in various ways. For example, rare earth permanent magnets produce more flux for their physical size than the magnetic energy (and resultant torque) produced by an induction motor's "squirrel cage rotor". As such, a PMAC motor can have higher power density than an equivalent rated IM.

Q: Are all AC drives suitable for operation of PMAC motors?

A: The drive used should be designed for use with permanent magnet machines. This is included in the specification for the drive and there is often a parameter to set to tell the drive that the motor attached is a PM motor. Some drives, not specifically designed for PM machines, will run and control a PM motor. Performance would typically not be as good in this case and this should be approved by the drive manufacturer before attempting. It is possible to damage the motor or drive if the drive is not set up properly or are mismatched.

Q: What is the operating temperature of SyMAX® PMAC motors, how does this compare with induction, and what is the benefit?

A: SyMAX® motors, because they are more efficient than induction motors and run cooler under the same load condition. This results in longer insulation and bearing life and reduces the amount of heat that goes into the operating environment. A general rule-of-thumb is that for every 10°C increase in operating temperature, insulation life is reduced by half; conversely every 10°C reduction in temperature doubles the insulation life. SyMAX® IHP (integral HP) motors are equipped with a full Class H insulation system but the design limits operating temperature to no more than Class B rise, providing very generous "thermal headroom"...and much longer insulation life.

Q: Is a PMAC motor immune from voltage spikes from the drive, causing insulation breakdown and shaft voltages?

A: SyMAX® motors are designed, in much the same way as inverter duty induction motors, to withstand voltage spikes from drives and wiring conditions. A major component is the patented Max Guard® insulation system. The lower operating temperature also contributes toward longer insulation life on a drive.

	SyMAX [®] Commercial	SyMAX [®] Industrial	
NEMA FRAMES	48, 56, 143/145T	182-215T	254-286T
IEC FRAMES	80	112-132	160-180
Electrical and Mechanical Features			
Ingress Protection (IP Code)	IP43 (IP54 or IP55 optional)	IP54 (IP55 or IP56 optional)	IP54 (IP55 or IP56 optional)
Frame construction	Steel	Cast Iron	Cast Iron
Enclosure	TENV (TEFC optional)	TEFC (TENV optional)	TEFC (TENV or TEBC optional)
End Shield material	Aluminum	Cast Iron	Cast Iron
Fan guard material (TEFC)	Polypropylene	Cast Iron	Cast Iron
Terminal box material	Steel	Cast Iron (Steel optional)	Cast Iron (Steel optional)
Power termination (see note 1)	Flying Leads (terminal board optional)	Flying Leads (terminal block optional)	Flying Leads (terminal block optional)
Standard terminal box position	F1 (IEC F3)	F1 (IEC F3)	F1 (IEC F3)
Auxiliary grounding provision (on frame foot)	None	Standard	Standard
Bearing system, C3 clearance	Sealed	Shielded with bearing caps	Shielded with bearing caps
Shaft seals	None	Slinger (V-Ring or Inpro optional)	Slinger (V-Ring or Inpro optional)
Regreasing provisions	None	Zerk fittings	Zerk fittings
Severe Duty features	None	Interior epoxy paint, dual cycle varnish treatment, terminal box gaskets, brass drain/breather	Interior epoxy paint, dual cycle varnish treatment, terminal box gaskets, brass drain/breather
Exterior paint	Black Enamel	Black Epoxy	Black Epoxy
Overload protection	None	N/C Thermostat	N/C Thermostat
Bearing Current Protection - OPTIONAL	Internal Shaft Grounding Ring	Internal Shaft Grounding Ring	Internal Shaft Grounding Ring
Insulation System	Class F Max Guard	Class H Max Guard	Class H Max Guard
Encoder provisions	Optional	Optional	Optional
Feedback devices - OPTIONAL	Hall effect sensor, encoders	Encoders, resolvers	Encoders, resolvers
Agency Recognition	UL, CSA, CE	UL, CSA, CE	UL, CSA, CE
Division 2 (CSA Certified) - OPTIONAL	No	Class I, Div 2, Groups A,B,C,&/or D	Class I, Div 2, Groups A,B,C,&/or D
End-of-Line production test report	Optional	Standard	Standard
Warranty term	3 years	3 years	3 years
Performance Features			
Efficiency level	NEMA Premium or higher	Ultra Efficient™ (IE4 or higher)	Ultra Efficient™ (IE4 or higher)
Cogging torque	Ultra Low	Ultra Low	Ultra Low
Operating temperature rise (maximum)	Class B rise or less	Class B rise or less	Class B rise or less
Variable Torque speed range (see note 2)	1-100% of base speed	1-100% of base speed	1-100% of base speed
Constant Torque speed range (see note 2)	1-100% of base speed	1-100% of base speed	1-100% of base speed
Constant power speed range (see note 2)	100-120% of base speed	100-120% of base speed	100-120% of base speed
Reserve Torque capability (up to 1 minute)	150%	150%	150%
Duty Cycle	Continuous	Continuous	Continuous
Ambient temperature range	-20 to +40°C	-20 to +40°C	-20 to +40°C
Altitude - maximum	3300 ft (1000 meters)	3300 ft (1000 meters)	3300 ft (1000 meters)
Balance Specification	NEMA Standard (Precision optional)	NEMA Standard (Precision optional)	NEMA Standard (Precision optional)

Note 1 - Optional terminal block (or board) is only available on single voltage motors. Terminal block requires cast iron terminal box.

Note 2 - Speed range is subject to VFD settings and capability. While the motor is fully capable of operating in a variable- or constant-torque mode from zero to base speed, performance characteristics such as speed or torque regulation are a function of the drive. Further, the maximum practical limit for most variable torque applications is 10:1. Constant power operation beyond base speed ("field weakening") is limited to 120% of base speed to protect the VFD from high counter EMF voltages should the drive lose control at high operating speeds. Contact Marathon Electric for specific performance requirements with the proposed VFD.

marathon™



100 E. Randolph Street, PO Box 8003
 Wausau, WI 54401-8003
 PH: 715-675-3311
www.marathonelectric.com

A Regal Brand



www.regalbeloit.com